

# SH-1003/1007-WAD

## Suction type gas detector

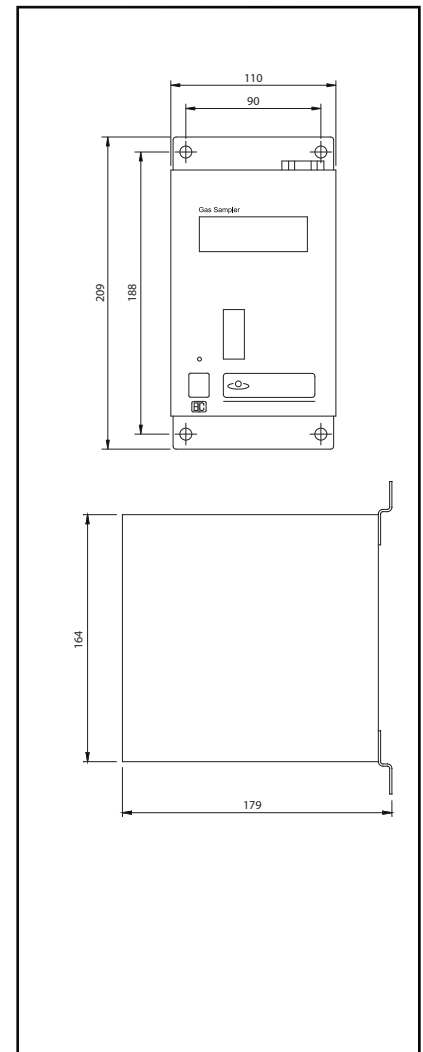

Part #	11901	11902
Detector model	SH-1003-WAD	SH-1007-WAD
Gas Sensor type	GS-[ ]HA/ES/MS/KTSS/HSR/HSC/ PID Optional/CDS	
Target gas	Please refer to the gas list	
Monitoring configuration	Single point, extractive	
Detection Principle	E-Chem, IR, Zirconium Cat.beat, PID & CEC technique <sup>1)</sup>	
Decomposer filament type	N.A. for SH-1003-WAD	Depending on target gas
Output signal	4-20 mA, 3 wire screened	
Accuracy	+/- 5% <sup>2)</sup>	
Alarm levels	Programmable (value/on-off) Alarm1, Alarm2, Warning	
Error reporting	Low Flow; Low Electrolyte; Sensor Missing	
Communication interfaces	RS-232; configuration and diagnostics (front RJ-45 connector) Optional through plugin module: RS-485; Profibus DP; MODBUS (JC-box required <sup>2)</sup> ) RS-485; SIMS (JC-box required <sup>3)</sup> )	
Indicator	140 x 32 dot matrix; blue/green VF display	
Sampling pump	Long life DC operated diaphragm pump	
Flow control	Optical/ electronic	
Operating temp.	0 - 40° C ; 32 - 104° F	
Operating humidity	5 % - 95% (non condensing)	
Installation	Indoor, wall-mount	
Tube connectors	In & out; 1/4 " NPT Female	
Power requirements	24 Volts DC	
Power consumption (max.)	14.4 Watt	
Dimensions (approx.)	(WxHxD) 110x209x179 mm	
Weight (approx.)	3.0 kg	



1) Combined Electrochemical Cell (CEC technique);

an electrochemical sensor combined with a decomposer unit.

2) Accuracy is subject to the calibration mixture.